

# 3G-324M Multimedia Gateway Demo

## Demo Description

This chapter provides a description of the 3G-324M Multimedia Gateway Demo. The 3G-324M Multimedia gateway demo is designed to show how a ‘thin’ 3G gateway can be configured within an IP Multimedia Server architecture. The 3G-324M Multimedia Gateway Demo consists of two parts

- 1) The m3g-sip\_gateway demo application that demonstrates 3G-324m calls and bridges 3G calls to a SIP endpoint, and
- 2) The Multimedia demo application, when configured to work with the m3g-sip\_gateway application, provides multimedia streaming to a remote 3G mobile endpoint.

The two applications work in tandem to demonstrate 3G-324m Multimedia functionality. A remote 3G caller places a call from a 3G network and the incoming call is identified to the m3g-sip\_gateway application which handles the 3G-324m protocol via the Dialogic 3G-324m API. The 3G call is bridged to an outbound SIP IP call. The MultiMedia Demo, which replicates an IP Multimedia Server, answers the SIP call from the m3g-sip\_gateway application and provides multimedia streaming over an IP channel. The demo configuration is described in “[Figure1: 3G-324m Multimedia Gateway Demo Configuration](#)”

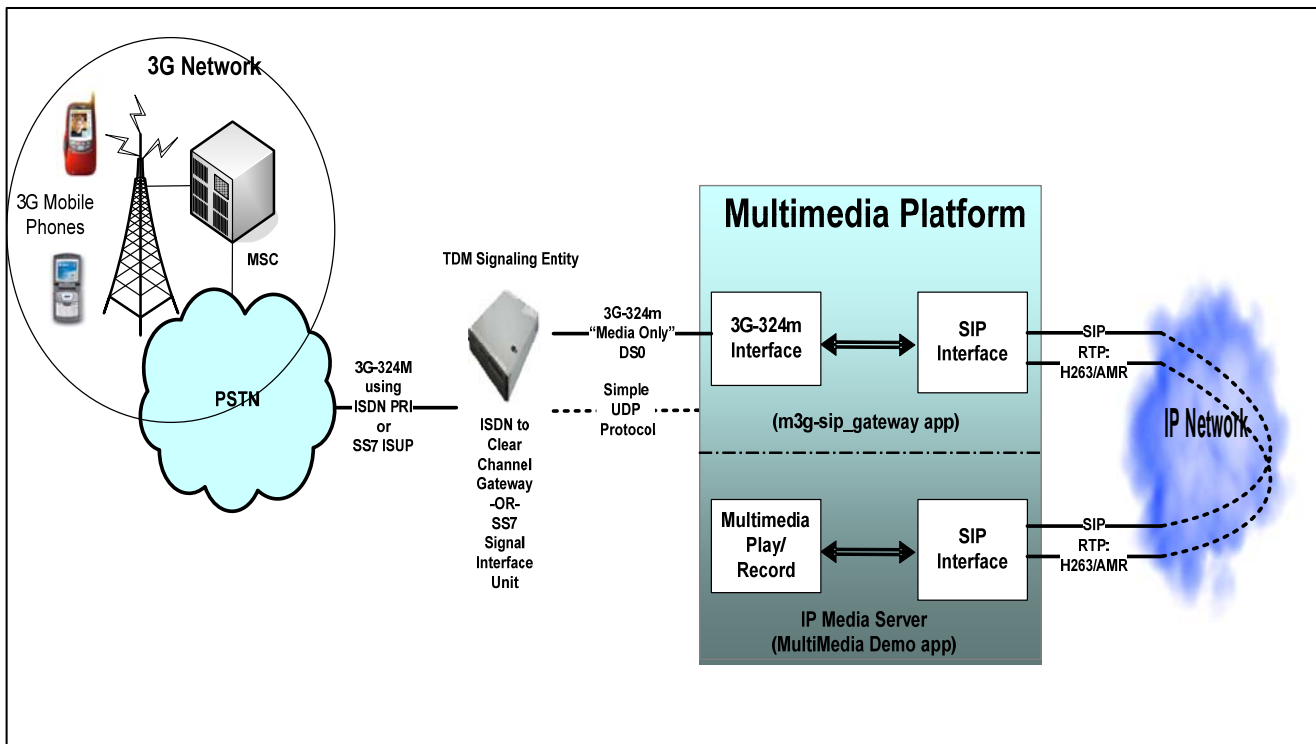

Figure 1: 3G-324m Multimedia Gateway Demo Configuration

It should be noted that the MultiMediaPlatform is a ‘Media Only’ Platform that does not provide TDM Signaling. Depending on the user’s TDM network, call signaling can be done with ISUP (SS7) or ISDN signaling and thus the demo setup requires a SS7 Signal Interface Unit or an ISDN to ClearChannel gateway to be used as a TDM Signaling Gateway. To facilitate incoming call identification, this demo was designed to accept a simple UDP Socket command from a TDM Signaling Gateway to identify that the bearer channel has been connected and 3G protocol can begin. An example of the UDP protocol is provided in the section “[Appendix I: Simple UDP Socket Protocol](#)”. For an example of how to create an ISDN to ClearChannel Gateway please see “[Appendix II: ISDN to ClearChannel Gateway](#)”.

The goal of this document is to describe the m3g-sip\_gateway application which demonstrates the Dialogic 3G-324m (m3g) library. This document also describes one possible configuration to provide 3G-324m multimedia services by connecting the m3g-sip\_gateway application to the Multimedia demo application. For a detailed description of the

Multimedia demo, beyond the configuration posted here, please see the “MultiMedia Demo Release Guide” for the corresponding MultiMedia Platform (MMP) release.

## **3G-324M - SIP Gateway Application (m3g-sip\_gateway)**

The m3g-sip\_gateway demo application is a 3G gateway application which demonstrates 3G mobile connectivity to a remote 3G-324m endpoint, using the Dialogic 3G-324m (m3g) library. The m3g-sip\_gateway demo application starts a 3G call session and then bridges an outbound call to a SIP endpoint.

The m3g-sip\_gateway demo application features the 3G-324m Library protocol connectivity software of the Dialogic MultiMedia Platform (MMP) providing 3G Audio and Video connectivity to a remote 3G mobile device. The application is based on the 3G-324m (m3g) Library for 3G connectivity, Global Call API for PSTN network interface connection, Global Call API for Session Initiation Protocol (SIP) call control, and the IP Media Library (IPML) for Real-Time Transport Protocol (RTP) media manipulation.

The key features the m3-sip\_gateway application demonstrates are:

- Uses GlobalCall PSTN network device to connect a ClearChannel E1(or T1) 64kbps data channel.
- Establishes a H223 data call session.
- Terminates 3G-324m protocol.
- Multiplexes/De-Multiplexes 3G-324m Audio/video data.
- Makes an outbound SIP call.
- Bridges a 3G call to a SIP call.
- Passes full-duplex Audio/Video data from a 3G mobile endpoint to a SIP endpoint
- Detects and forwards RFC2833 DTMF digits between endpoints.
- (optionally) Receives remote udp socket indication of PSTN call.

## **3G-324M Multimedia Using Multimedia Demo**

Used in conjunction with the Dialogic Multimedia Demo (for HMP or MMP), the m3g-sip\_gateway application can demonstrate Video mail and video portal/video blogg capability to a 3G mobile. The Dialogic MultiMedia Demo is shipped with the Dialogic MMP release and can be used on the same system as the m3g-sip\_gateway application or on a separate system. The combination of the m3g-sip\_gateway application and the MultiMedia Demo application provide a 3G gateway plus IP Media Server architecture. The goal of this document is to describe the configuration and setup procedure for using the m3g-sip\_gateway application and point out how it interacts with the MultiMedia Demo to offer video mail and video portal features to a remote 3G endpoint.

The m3g-sip\_gateway used with the multimedia demo application demonstrates two use cases:

- 3G Video mail/Video blogg – 3G mobile device can record an audio/video clip and play it back at a later time.
- 3G Video portal – 3G mobile device can select video clips from a menu and stream to the 3G mobile device

## **System Requirements**

### **Hardware/Software Requirements**

For hardware requirements, refer to the Release Guide (or Release Notes) for the MultiMedia Platform (MMP) software version you are using. MultiMedia Platform hardware required include:

1. Dialogic Multimedia Platform Advanced ATCA blade with AMC.
2. Dialogic Multimedia Platform IP+TDM Rear Transition Module (RTM) module
3. Dialogic Multimedia Platform RTM breakout box kit.

In addition to meeting the software license requirements in the MultiMediaPlatform release documentation, you will need

1. On the 3G side:
  - a. Connection to a 3G Network and a 3G mobile phone.
  - b. -OR- A 3G simulation endpoint, such as the Radvision ProLab, to initiate a 3G call.
2. On the SIP side:
  - a. The Dialogic MultiMedia Demo Application configured as described in this document.

- b. -OR- A SIP IP phone with AMR codec capability, such as Kapanga Softphone.
  3. A TDM Signaling Gateway:
    - a. An ISDN to ClearChannel gateway.
    - b. -OR- A SS7 signaling endpoint.

## Preparing to Run the Demo

This chapter describes what you need to do before running the m3g-sip\_gateway demo.

### Connecting to External Equipment

This section describes the external connections required for the m3g-sip\_gateway demo. The demo requires:

1. Connection to a 3G Network
2. TDM Signaling Gateway
3. (optional) Simple UDP Socket Protocol – See Appendix I

### Connection to a 3G network.

It is expected that the user has a connection to a 3G network and that data from a 3G call can be routed to specified [E1/T1] ds0 bearer timeslots terminated on the MultiMediaPlatform RTM. The PSTN interface of the MultiMedia Platform (MMP) can be configured to E1 or T1 and provides a ClearChannel link to the PSTN network. Once configured, the MultiMedia Platform (MMP) sets up 64kbps 'Media only' ds0 channels to the 3G network. Please see "[Figure 1: 3G-324m Multimedia Gateway Demo Configuration](#)"

### TDM Signaling Gateway:

Call signaling to the PSTN network is normally done with ISUP (SS7) or ISDN signaling. ISUP TDM signaling can be terminated on an SS7 blade using SS7 software products available from Dialogic. Depending on the solution scale and resources required by the application, the SS7 signaling server and application functions can be combined on the same blade. For an ISDN connection to the network, a dialogic product such as the DMV1200B-TEP board can be configured to provide ISDN to ClearChannel routing. Please see "[Appendix II: ISDN to ClearChannel Gateway](#)"

*Please note:* The MultiMediaPlatform provides a ClearChannel TDM connection (i.e., bearer channel connection) for 'Media only' traffic through the RTM Module. Incoming call control indication from the PSTN network is outside the scope of the m3g-sip\_gateway application. The Simple UDP Socket protocol can be used to remotely send Connect and Disconnect command messages to the m3g-sip\_gateway application. An example is provided in the section "[Appendix I: Simple UDP Socket Protocol](#)"

## Editing the Configuration File

This section discusses how to configure the demo for your system. It contains the following topics:

- o [Configuration File Location](#)
- o [Editing the config.txt Configuration File](#)

### Configuration File Location

The demo runs with the help of the configuration file named *config.txt*. This configuration file is essential for providing the program with required configuration information. Use a text editor and open the file from:

- o Linux: \${DIALOGIC\_DIR}/demos/3GDemo/m3g-sip\_gateway/Release

### Editing the config.txt Configuration File

Before running the m3g-sip\_gateway demo, modify the *config.txt* file to reflect your system Environment and 3G-324m settings.

**Logging (ON/OFF):**

This configuration section specifies whether application logging will be enabled (ON) or not (OFF). If logging is enabled, log output will be collected in the file, *logfile.txt*

```
#####  
# Logging (ON/OFF):  
#####  
LOG: ON  
#####
```

### SIP\_INFO\_DTMF (ON/OFF):

This configuration section specifies whether the application will use SIP Info messages for forwarding DTMF digits. In SIP\_INFO\_DTMF=ON, a H245 User Input Indication DTMF event from the 3G network will trigger an outbound SIP Info message to the SIP endpoint. In SIP\_INFO\_DTMF=OFF, a SIP Info message will not be sent to the SIP endpoint. Instead, on reception of a H245 User Input Indication DTMF from the 3G network, the 3G-324m library response will be based on the board parameter setting PRM:DIGIT\_TO\_MEDIA (if enabled, DTMF xfer mode = RFC2833).

Note: The DTMF settings between the m3g-sip\_gateway and the MultiMediaDemo must match, either 1) SIP\_INFO or 2) RFC2833.

```
#####  
# SIP INFO DTMF (ON/OFF):  
#####  
SIP_INFO_DTMF: ON  
#####
```

### H.245 Operating Mode:

This configuration parameter selects Automatic or Manual Operation for H.245 connection. Before any 3G-324m signaling can take place, the call must be established and connected outside this application. In Automatic mode (AUTO), the application will automatically call m3g\_StartH245() once the internal connections are made and repeat this until the session is started. In Manual mode (MANUAL), the trigger for m3g\_StartH245() (ie, call establishment) must be supplied by an external source. This external trigger can be a manual keyboard hit to connect the channel or a remote socket hit which simulates an incoming call via the Simple UPD protocol. The format to set the H245 Operating mode = *MODE:<AUTO/MANUAL>*

```
#####  
# H.245 Operating Mode:  
# AUTO:=Automatic  MANUAL:= User prompts or network socket control  
#####  
MODE: MANUAL  
#####
```

### Endpoint Configuration:

This parameter section designates the endpoint configuration setup for the application. There are two types of endpoints, m3g endpoints and sip endpoints. The m3g endpoint specifies the devices used to connect to a remote 3G-324m device. The sip endpoint specifies the devices used to connect to a remote SIP device. Each m3g endpoint, must have a corresponding sip endpoint.

#### m3g Endpoint:

The m3g endpoint specifies the devices used in making a 3G connection to a 3G-324m device.

Endpoint Number – EP:<n> – The numerical endpoint number.

Endpoint type – m3g – The m3g endpoint type designates the 3G side of the call.

Control Device – m3gB<x>T<y> - Specifies the m3g device that handles the 3G call for this endpoint.

Stream Device – dtiB<x>T<y> - Specifies the data channel that carries the H223 multiplexed data.

Local Peer - <x> - Specifies the corresponding sip endpoint for this m3g endpoint.

Loopback Peer - <x> - Specifies the corresponding m3g endpoint for m3g to m3g loopback mode.

Map ID - <text> – Specifies a unique text string to identify an endpoint for socket command use.

#### sip Endpoint:

The sip endpoint specifies the devices used to make a sip connection.

Endpoint Number – EP:<n> – The numerical endpoint number.

Endpoint type – sip – The sip endpoint type designates the SIP side of the call.

Control Device – iptB<x>T<y> - Specifies the ipt device that handles the sip call control for this endpoint.

Stream Device – ipmB<x>T<y> - Specifies the ipm device used for RTP data traffic.

Local Peer - <x> - Specifies the corresponding m3g endpoint for this sip endpoint.

Loopback Peer - 0 – This parameter is not used for the sip endpoint.

Map ID – none – This parameter is not used for the sip endpoint.

Example: In the example below, one pair of endpoints is configured - one m3g endpoint and one sip endpoint.

**M3g endpoint** - The m3g endpoint is configured to use device m3gB1T1 to run the 3G-324m protocol and connect to the network through DTI device dtiB1T31. The m3g Local peer is EP:2, the sip endpoint. The map ID is a unique text string to identify an endpoint for socket command use. In this example an ISDN to ClearChannel gateway passes the identifier string of the inbound call device.

**Sip Endpoint** - The sip endpoint is configured to use iptB1T3 for SIP call control and ipmB1C3 for RTP media traffic. The sip local peer is EP:1, the m3g endpoint.

```
#####
# Endpoint Endpoint Control Stream Local Loopback Map ID
# Number Type Device Device Peer Peer
#####
EP: 1 m3g m3gB1T1 dtiB1T31 2 0 :N_DTIB1T30:P_ISDN
EP: 2 sip iptB1T3 ipmB1C3 1 0 none
#####
```

### Board Parameter Settings:

This parameter configuration section allows the user to set application specified board parameters specified by the M3G\_PARM\_INFO parameter types. The format to set a board parameter = *PRM:<Parameter Name> <value>*

Example: In the example below, 3 board parameters are enabled:

1. DIGIT\_TO\_MEDIA=1, User Input Indication to RFC2833 DTMF translation
2. FASTUDPATE\_TO\_H245=1, Fast Video Update relay to H245
3. H245\_TERMINAL\_TYPE=90, H245 Terminal type value set to 90

```
#####
# Board Parameters:
# Possible Settings:
# PRM: DIGIT_TO_MEDIA 1 # Activate UII-RFC2833 DTMF translation (values: 0/1)
# PRM: DIGIT_TO_H245 0 # Activate RFC2833-UII DTMF translation (values: 0/1)
# PRM: FASTUDPATE_TO_MEDIA 0 # Activate Video Fast Update relay to Media (values: 0/1)
# PRM: FASTUDPATE_TO_H245 1 # Activate Video Fast Update relay to H245 (values: 0/1)
# PRM: SKEWINDICATION # Set Skew Indication (values: )
# PRM: AUDIOVISUALSYNCH # Set AudioVisual Synch (values: )
# PRM: RETRANSMIT_ON_IDLE # Set Retransmit on Idle (values: )
# PRM: H245_TERMINAL_TYPE 90 # Set H245 Terminal Type (values: 0-255)
# PRM: MAX_CCSSL_SEGMENT 255 # Set Maximum CCSSL Segment size (values: 0-255)
#####
PRM: DIGIT_TO_MEDIA 1
PRM: FASTUDPATE_TO_H245 1
PRM: H245_TERMINAL_TYPE 90
#####
```

### Event Notification:

This parameter configuration section allows the user to specify the maskable 3G-324m library events reported to the application as enabled by m3g\_EnableEvents() or disabled by m3g\_DisableEvents(). Parameters in this section overwrite the default values.

The parameter format to enable the event = *ENEV:<Event Name>* and to disable the event = *DSEV:<Event Name>*

Example: In the example below, Event Notification is enabled for Master Slave Determination event reporting and MES event reporting.

```
#####
# Event Notification:
# ENEV:=Enable DSEV:=Disable
# Possible settings:
# ENEV: H245_UII_EVT # H245 User Input Indication (UII) Digit received event.
# ENEV: FASTUPDATE_EVT # H245 Fast Video Update (FVU) received event.
# ENEV: TEMP_SPAT_TRDFF_EVT # H245 Temporal Spatial Tradeoff received event
# ENEV: VIDEO_FREEZE_EVT # H245 Video Freeze received event
# ENEV: SYNC_GOB_EVT # H245 Video Synch every GOB received event*
# ENEV: SKEW_INDICATION_EVT # H245 Skew Indication received event
# ENEV: VERBOSE_MSD_EVT # Master/Slave Determination event reporting
# ENEV: MES_EVTS_EVT # MES event reporting
# (note: events designated with * are disabled by default)
#####
ENEV: VERBOSE_MSD_EVT
ENEV: MES_EVTS_EVT
#####
```

### H223 Session:

This parameter configuration section allows the user to specify parameters related to the physical multiplex layer or H223 Session for each endpoint or group of endpoints based on the fields of the M3G\_H223\_SESSION data structure. The parameter format for configuring the H223 Session = HSES:<m3g endpoint/m3g endpoint range> < defaultH223MuxLevel> <maxALSDUSize> <isWSNRPEnabled (T/F)> < isMultipleMsgsPerPdu (T/F)>

Example: In the example below, the H223 session for m3g endpoint 1 is configured to Level 2 with a MaxAL2 size=512, WSNRP enabled and Multiple pages per PDU enabled.

```
#####
# H223 Session:
# Default H223MuxLevel: L0 - Level0
#           L1 - Level1
#           L1D - Level1 Double Flags
#           L2 - Level2
#           L2H - Level2 Optional Header
#           L3 - Level3
#           L3H - Level3 Optional Header
# Endpoints Mux  MaxAL2  WSNRP  MultipleMsgs
#           Lvl  Size    (T/F)  Per PDU (T/F)
#####
HSES: 1  L2  512    T      T
#####
```

### H223 Capabilities:

This parameter configuration section allows the user to specify the H223 capabilities for the m3g endpoint or group of m3g endpoints based on the fields of the M3G\_H223\_CAPABILITY data structure. The parameter format for configuring the H223 Capabilities = HCAP:<m3g endpoint/m3g endpoint range> <adaptationLayerMedia> <maxAL2SDUSize> <maxAL3SDUSize> <frameH223AnnexA(T/F)> <frameH223DoubleFlag(T/F)> <frameAnnexB(T/F)> <frameAnnexBWithHead(T/F)> <rsCodeCapability(T/F)> <mobileOpXmitCap(T/F)> <bitRate>

Example: In the example below, the H223 capabilities for m3g endpoint 1 is configured to enable All AdaptationLayers (63 = 0x3f) with max AL2 and AL3 SDU size =200. H223 Capability options frameH223AnnexA, frameH223DoubleFlag, frameAnnexB, frameAnnexBWithHead, rsCodeCapability, and mobileOpXmitCap are all enabled and the unframed bit rate is 64kbps.

```
#####
# H223 Capabilities:
# Options:
# AL: AudioAL1 0x01  Bitrate: 320 or 640 (x 100bps)
#   AudioAL2 0x02
#   AudioAL3 0x04  MobileOpXmtCap: none: 0x00
#   VideoAL1 0x08  mode change: 0x01
#   VideoAL2 0x10  AnnexA: 0x02
#   VideoAL3 0x20  AnnexADblFlag 0x04
#                   AnnexB 0x08
# MaxAL2Size:0-64k  AnnexBwHeader 0x10
# MaxAL3Size:0-64k
# Endpoints AL AL2 AL3 AnxA Dbl AnxB AnxB RS MblOp Bit
#           Size Size Frame Flag Frame Hdr Code Xmt Rate
#####
HCAP: 1  63  200 200  T  T  T  T  T  T  640
#####
```

### Terminal Capabilities:

This parameter configuration section allows the user to specify the Terminal Capabilities for each m3g endpoint or group of m3g endpoints. Terminal Capabilities are supported Audio/Video coders designated by the endpoint for each 3G call. Possible values for terminal capabilities include amr and g723 for audio coder and h263 for video coder. The parameter format for configuring the Terminal Capabilities = MCAP:<m3g endpoint/m3g endpoint range> <amr> <g723> <h263>

Example: In the example below, the Terminal Capabilities for m3g endpoint 1 is configured to support AMR for audio and H.263 for video.

```
#####
# Terminal Capabilities:
# Endpoints Capabilities
#####
MCAP: 1  amr h263
#####
```

### OpenLogicalChannel H223 Parameters:

This parameter configuration section allows the user to specify the OpenLogicalChannel Parameters for the H223 physical multiplexing layer based on the fields of the M3G\_H223\_LC\_PARAMS data structure. The parameter format for configuring the Open Logical Channel H223 Parameters = HOLLC:<m3g endpoint/m3g endpoint range> <Audio adaptationLayerType> <Video adaptationLayerType> <SegmentableAudio(T/F)> <SegmentableVideo(T/F)> <AL3\_ControlFieldSize> <AL3\_SendBufferSize>

Example: In the example below, the OpenLogicalChannel H223 Parameter for m3g endpoint 1 is configured to support AL2 without segmentation for audio and AL3, fieldsize=0, buffersize=256 with segmentation for video.

```
#####
# OpenLogicalChannel H223 Parameters:
#
# ALTypes: AL1_FRM
#   AL1
#   AL2_SEQ
#   AL2
#   AL3
#
# Endpoints Audio Video Segmentable Segmentable AL3 Control AL3 Send
#           AL  AL  Audio   Video   Field Size   Bufr Size
#####
HOLLC: 1  AL2  AL3   F       T           0         256
#####
```

### SIP Endpoint Parameters:

This parameter configuration section allows the user to specify the IP addresses for the SIP call.

Note: When using the m3g-sip\_gateway and the MultiMediaDemo in the same system, use the full ip addresses not the local loopback address. For MultiMediaPlatform this should be *eth6*.

Orig SIP Addr – is the Origin SIP address for the m3g-sip\_gateway application in the form <phone number>@<ip address>:<sip udp port>

Dest SIP Addr – is the Destination SIP address for outgoing sip call in the form <phone number>@<ip address>:<sip udp port>

Example: In the example below, the SIP Endpoint is configured for the MultiMediaPlatform with *eth6* ip address = 146.152.99.121. Since the m3g-sip\_gateway and MultiMediaDemo are used on the same system, the source and destination ip addresses are the same but the ports are different.

```
#####
# SIP Endpoint Parameters
#
# Although there may be multiple SIP endpoints, they all share the same
# IP and SIP origin and destination addresses.
# "Origin" is the m3g-SIP gateway address/port
# "Destination" is the MMDemo address/port
#
#           Orig IP Addr   Dest IP Addr   Orig SIP Addr   Dest SIP Addr
#####
SIPAD: 146.152.99.121 146.152.99.121 123@146.152.99.121:5062 1000@146.152.99.121:5060
#####
```

## General Demo Configuration

The m3g-sip\_gateway application was designed to be used together with the MultiMedia Demo application in order to provide audio/video multimedia streaming to a 3G mobile device. The m3g-sip\_gateway application used together with the MultiMedia demo application demonstrates an inbound call from a 3G mobile device that is bridged to a SIP call that terminates at the Multimedia demo. The Multimedia demo provides Audio/Video play and record capability and real time streaming to the 3G mobile device. Both applications, m3g-sip\_gateway and the multimedia demo, can be used on the same system or two separate systems.

The call flow of the m3g-sip\_gateway application used with the MultiMedia Demo begins with the 3G caller. The 3G mobile device makes an inbound call handled by the 3G-324m API of the m3g-sip\_gateway application. Upon connection to the 3G mobile device, the m3g-sip\_gateway application makes an outbound sip call to the MultiMedia Demo on the pre-configured SIP endpoint. The MultiMedia Demo will answer the SIP call and play Audio/Video menus to the 3G mobile device. The 3G mobile caller can use the functionality of the MultiMedia Demo to

- 1) Leave or retrieve a video mail/video blogg .
- 2) Receive streamed video clips without having to wait for download and buffering.

To configure the Multimedia Demo application to provide Video Mail/Video Blogg or Video portal functionality, the following configuration must be set:

### **M3g-sip\_gateway Required Configuration:**

*SIP Endpoint Parameter* – The m3g-sip\_gateway application must be configured to make a SIP call to the Multimedia Demo. Thus, the Destination SIP Address (*Dest SIP Addr*) must be configured to *<MultiMediaDemo Phone number>@<MultimediaDemo IP addr>:<Multimedia SIP udp port>*. Note: If the m3g-sip\_gateway application and the Multimedia demo are used on the same system, the IP address will be the same, but the SIP udp port must be different.

### **MultiMedia Demo Required Configuration:**

*Use AMR coder* –

The MultiMediaDemo must be configured to ‘useamrcoder=true’ in the *mmdemo.cfg* file for connection to the m3g-sip\_gateway application. Since there is no transcoding in the m3g-sip\_gateway application, the MultiMediaDemo must use the AMR codec to stream audio packets though the m3g-sip\_gateway to the remote 3G mobile device.

### **MultiMedia Demo Optional Configurations:**

The MultimediaDemo Application can be configured with a few optional settings:

*Use SIP Info messages for DTMF* –

The configuration setting, ‘usesipinfodtmf=true’ in the *mmdemo.cfg* file can be used to configure the MultiMediaDemo to receive SIP Info messages for DTMF detection rather than using RFC2833 digit detection. This setting corresponds to the m3g-sip\_gateway *config.txt* setting, SIP\_INFO\_DTMF: ON, which specifies when the m3g-sip\_gateway application gets an H245 digit from the remote 3G mobile device to forward a SIP\_INFO message rather than sending an RFC2833 digit.

*Periodic I-Frame generation* –

With a Makefile compilation define, the MultiMediaDemo can be configured to provide periodic I-Frame requests during file recording. When *PERIODICIFRAMES* is enabled in the Makefile, the MultimediaDemo will use a periodic timer to send a SIP I-Frame update request to the m3g-sip\_gateway application at a periodic rate set by ‘*IFrameInterval = <numer of seconds>*’ in the *mmdemo.cfg* file. The m3g-sip\_gateway application will translate the SIP I-Frame update requests into Fast Video Update (FVU) requests sent by the 3G-324m protocol to the 3G mobile endpoint that is requesting Audio/Video data to be recorded. The purpose of this parameter is to provide a mechanism to vary the I-frame request rate so that a recorded file will more quickly receive a full Video I-frame.

```
In ${DIALOGIC_DIR}/demos/MultiMediaDemo/Makefile:
# Send out periodic IFrame requests in SIP INFO messages
# when in a record mode. Time is set in the config file
PERIODICIFRAMES = -DPERIODIC_IFRAMES
```

*3G to 2G call bridging* –

With a Makefile compilation define, the MultiMediaDemo can be configured to provide the dtmf controlled option to make an audio connection from the 3G mobile endpoint to a 2G “audio only” device. The purpose of this parameter is to provide a mechanism to bridge audio from a 3G mobile device to a 2G mobile device (or PSTN endpoint). The bridging call can be connected by the 3G mobile device user by pressing digit ‘4’ and disconnected by pressing the digit ‘5’. This parameter enables an audio connection to GlobalCall DTI device dtiB2Tx. The isdngatewayip and isdngatewayport values are set in the *mmdemo.cfg* file to provide a mechanism to send a UDP socket command and notify a destination of the dti timeslot and phone number.

```
In ${DIALOGIC_DIR}/demos/MultiMediaDemo/Makefile:
# This enables a GC/DTI connection using dtiB2
# DTMF "4" will enable the connection, and "5" will disable it in any of the
# demo menus
TDMAUDIO = -DTDM_AUDIO
```

Example of the *mmdemo.cfg* file:

```
#####
#Multimedia Demo Parameters
```

```

#
# NumberOfCalls - is the number of channels to use
# calltype - is the protocol used - h323 or sip
# TraceFlag - turns tracing on - extensive logging to screen.
# Use only when running 1 or 2 channels.
# avfiledir - the directory which contains the standard set of audio/visual files for menus and clips
# proxyip - is the IP address of the SIP proxy server
# sipudpport - is the UDP port number to use - default is 5060 in SIP
# PhoneNumber - is a unique phone number that every HMP channel will use
# starting with this number - incremented by 1
# useamrcodec - if true, use AMR codec. Otherwise, G.711 will be used.
# usesipinfodtmf - if true, use SIP INFO messages for DTMF transmittal instead of RFC2833 in RTP
# repeatmenus - if true, repeat menu play when done. Otherwise play menus once
#
# These parameters are only valid if their functionality is compiled
# into the demo. Otherwise they are ignored
# See the Makefile for details
# IFrameInterval - frequency (in seconds) of SIP INFO messages containing IFrame
# update requests.
# isdngatewayip - IP address of ISDN gateway for 2G connection command socket
# isdngatewayport - port of ISDN gateway for 2G connection command socket
#####
numberofcalls = 1
calltype = sip
traceflag = true
avfiledir = ./avfiles/lores
proxyip = 10.10.10.10
sipudpport = 5060
PhoneNumber = 1000

##### 3G-324M Multimedia Gateway Settings #####
useamrcodec = true
usesipinfodtmf = true
repeatmenus = true
IFrameInterval = 5
isdngatewayip = 127.0.0.1
isdngatewayport = 40122

```

## Compiling and Linking

This section contains the following information:

[Linux Procedure for compiling and Linking](#)

### ***Linux Procedure***

To compile the source code for the m3g-sip\_gateway demo application, perform the following:

1. Go to this location:

```

${DIALOGIC_DIR}/demos/3GDemo/m3g-sip_gateway

```

2. At the command prompt, type

```

make clean; make

```

If you have added or changed files, perform the following to compile the project:

1. Put the files in

```

${DIALOGIC_DIR}/demos/3GDemo/m3g-sip_gateway

```

2. Modify the Makefile to take into account the new files generated.

3. At the command prompt, type

```

make clean; make

```

Successful compilation results in an executable called *m3g-sip\_gateway* at the following location.

```

${DIALOGIC_DIR}/demos/3GDemo/m3g-sip_gateway/Release

```

### ***Compiling the MultiMedia Demo for 3G-324M Multimedia***

To compile the source code for the MultiMedia demo application, perform the following:

1. Go to this location: `${DIALOGIC_DIR}/demos/3GDemo/MultiMedia/MultiMediaDemo`

2. Configure the *Makefile* and *mmdemo.cfg* files with 3G-324M MultiMedia Configuration options.
3. At the command prompt, type  
make clean; make
4. Successful compilation results in an executable called *MultiMediaDemo* at the following location.  
\${DIALOGIC\_DIR}/demos/3GDemo/MultiMedia/MultiMediaDemo

## Running the Demo

### Starting the Demo

This section describes how to start the m3g-sip\_gateway demo and contains the following information:

- o [Preparation](#)
- o [Linux Procedure](#)
- o [Sample Output](#)

### Preparation

Before running the demo, be sure to follow the instructions provided in, [“Preparing to Run the Demo”](#).

The Dialogic® MultiMedia Platform(MMP) software is automatically started during system boot-up. The appropriate scripts have been invoked and the necessary services started.

### Linux Procedure

To start the m3g-sip\_gateway demo, perform the following:

1. Launch a terminal window to start typing commands.
2. Change to the following directory:  
\${DIALOGIC\_DIR}/demos/3GDemo/m3g-sip\_gateway/Release
3. At the command prompt, type ./m3g-sip\_gateway.
4. The m3g-sip\_gateway application will arm for incoming 3G calls.

### Sample Output

The example below shows the sample display output for a one m3g device (endpoint M3G 1) configured to bridge to one sip device (endpoint SIP 2). The m3g device is armed and ready to synchronize to H223 data after indication of an incoming call. The sip call is idle, waiting for the m3g state machine to direct an outbound call. The bridge device (device BRG 1) displays the state machine coordination between the m3g device (M3G 1) and the sip device (SIP 2)

```

=====
3G-324M - SIP GATEWAY DEMO
=====
STATE:  AUDIO:      VIDEO:      MISC.
        TxLCN: RxLCN: CAP: TxLCN: RxLCN: CAP:  CMD/IND:
=====
M3G 1: H245_INACTIVE  0  0  none  0  0  none
SIP 2: IDLE           0  0  n/a  0  0  n/a
BRG 1: IDLE           M3G:1 <-> SIP:2

PROMPT: (Q)uit, (C)onnect, (D)isconnect, (S)end

```

### Starting the MultiMedia Demo for 3G-324M Multimedia

This section describes the procedure to start the MultiMedia Demo to provide Audio/Video multimedia streaming to a 3G device. Before making any 3G calls to the m3g-sip\_gateway application, start the Multimedia demo application with the required configuration from section [“Configuring the MultiMedia Demo as a SIP Media Server”](#). This will arm the MultiMedia Demo and ready it for incoming SIP calls. For more information about the MultiMedia Demo, please see the [“MultiMedia Demo Release Guide”](#) for the corresponding MultiMediaPlatform release.

### Using the Demo

This section describes how to use the m3g-sip\_gateway demo.

Start the demo as described in [“Starting the Demo”](#).

## **Connecting a call**

Once the m3g-sip\_gateway application is started, it is armed and ready to receive 3G calls on the m3g control devices connected to the DS0 timeslots specified by the dti streaming devices. The user can connect an endpoint manually by typing **c**. The user will then be prompted to select the endpoint number to connect, **Endpoint number?** Type the number of the m3g endpoint to be connected. This will initiate the m3g-sip\_gateway application to start H223 synchronization on the m3g control device. The manual method allows the user to start synchronization of the H223 stream. Once the 3G-324m protocol recognizes the H223 bit pattern in the data stream, call initialization, OpenLogicalChannels and StartMedia begins automatically.

### Remote “Connect” command:

Alternatively, the m3g-sip\_gateway application will accept a remote network indication of a Call Connect event. A simple UDP socket “Connect” command can be used to signal an incoming PSTN call from a remote signaling source. The remote command should be issued to signal the PSTN connection of the incoming 3G call at the DS0 timeslot of the dti stream device. The format for the remote Connect command is “C <Map ID> <calling phone number>:<called phone number>”.

Remote “Connect” Command Parameters:

C = Connect

<Map ID> = Specifies a unique text string to identify an endpoint for socket command use.

<calling phone number> = The calling party’s phone number

<called phone number> =The called party’s phone number

An example of the UDP protocol Remote “Connect” Command is provided in the section [“Appendix I: Simple UDP Socket Protocol”](#).

## **Disconnecting a Call**

To stop the m3g-sip\_gateway demo during a call, simply hang up the 3G mobile device.

The user can disconnect an endpoint manually by typing **d**. The user will then be prompted to select the endpoint number to disconnect, **Endpoint number?** Type the number of the m3g endpoint to be disconnected. This will disconnect the m3g endpoint allowing it to re-arm for the next call, terminate the corresponding SIP call and return the associated bridge and sip devices to and IDLE state.

### Remote “Disconnect” command:

Alternatively, the m3g-sip\_gateway application will accept a remote network indication of a Call Disconnect event. A simple UDP socket “Disconnect” command can be used to signal termination of a PSTN call from a remote signaling source. The remote command should be issued to signal the PSTN termination of the 3G call at the DS0 timeslot of the dti stream device. The format for the remote Connect command is “D <Map ID>”.

Remote “Disconnect” Command Parameters:

D = Disconnect

<Map ID> = Specifies a unique text string to identify an endpoint for socket command use.

An example of the UDP protocol Remote “Disconnect” Command is provided in the section [“Appendix I: Simple UDP Socket Protocol”](#).

## **Exiting the Demo**

To exit the m3g-sip\_gateway demo, type **q** and press **Enter** to quit. Wait for the demo to shut down. It takes about three to five seconds.

# Appendix I: Simple UDP Socket protocol

This chapter suggests one method to provide incoming call signaling identification to the m3g-sip\_gateway demo.

## Simple UDP Socket protocol:

TDM SS7 or ISDN call signaling is beyond the scope of the m3g-sip\_gateway application. Therefore the m3g-sip\_gateway application provides a simple UDP socket command method for indicating an incoming TDM call and initiating the 3G-324m protocol. The UDP socket command protocol can be installed at the SS7 signaling entity or at the ISDN to ClearChannel gateway entity. On an incoming call, a remote 'connect' message is sent to the m3g-sip\_gateway application to signify that an incoming call has been connected to a particular timeslot. The UDP socket commands provide a remote network indication of the incoming connect or disconnected call similar to a user keyboard indication. The format of udp socket command for Connect is ['C <Map ID> <calling number>:<called number>'] and the format of the disconnect command is ['D <Map ID>']. This is the preferred method to indicate an incoming connect or disconnect on a particular ds0. Sample code for this socket command is included below.

```
// Remote Mux3G Gateway Macro Declarations
#define APP_CMD_PORT      40121      // cmd port used by M3G Gateway
#define REMOTE_HOST      "146.152.80.84" // address of M3G Gateway

//To Connect
// send connect command to Mux3G Gateway
char command[80];
sprintf(command, "C %s %s:%s",pline->devname, "1111111111", "2222222222");
sendCmdToMux3G(command);

//To disconnect
// send disconnect command to Mux3G Gateway
char command[80];
sprintf(command, "D %s %s",pline->devname);
sendCmdToMux3G(command);

/*****
*      NAME: sendCmdToMux3G
*      DESCRIPTION: Send a UDP Packet to the Mux3G Gateway
*                  to command the gateway to perform an action.
*      INPUT: cmd - command as string
*      RETURNS: none
*****/
void sendCmdToMux3G(char* cmd)
{
    static int initialized = 0;
    static int sockHand;
    struct sockaddr_in server;
    int length;
    int buflen;

    if (! initialized)
    {
        sockHand = socket(AF_INET ,SOCK_DGRAM , IPPROTO_UDP);
        if (sockHand < 0)
        {
            printandlog(ALL_DEVICES, MISC_WITH_NL, NULL, "sendCmdToMux3G() socket() failure", 0);
            return;
        }
        initialized = 1;
    }

    server.sin_family = AF_INET;
    server.sin_addr.s_addr = inet_addr(REMOTE_HOST);
    server.sin_port = htons(APP_CMD_PORT);
    length = sizeof(server);

    buflen = strlen(cmd) + 1;

    if (sendto(sockHand,
               cmd,
               buflen,
```

```
0,  
(struct sockaddr*)&server,  
length) != buflen)  
{  
    printandlog(ALL_DEVICES, MISC_WITH_NL, NULL, "sendCmdToMux3G() sendto() failure", 0);  
}  
}
```

## Appendix II: ISDN to ClearChannel Gateway

This chapter suggests one method to provide an ISDN to ClearChannel gateway

### ***ISDN to ClearChannel Gateway as a TDM Signaling Entity:***

The MultiMediaPlatform provides a ClearChannel TDM connection (i.e., bearer channel connection) for ‘Media only’ traffic through the RTM Module. Incoming call control indication from the 3G PSTN network is normally done with ISDN or ISUP (SS7) signaling and depends on the 3G PSTN network connection. This section describes one method to create a TDM signaling entity for an ISDN connection by detailing an ISDN to ClearChannel gateway. This example is provided as a quick method to provide incoming call indication to the m3g-sip\_gateway application.

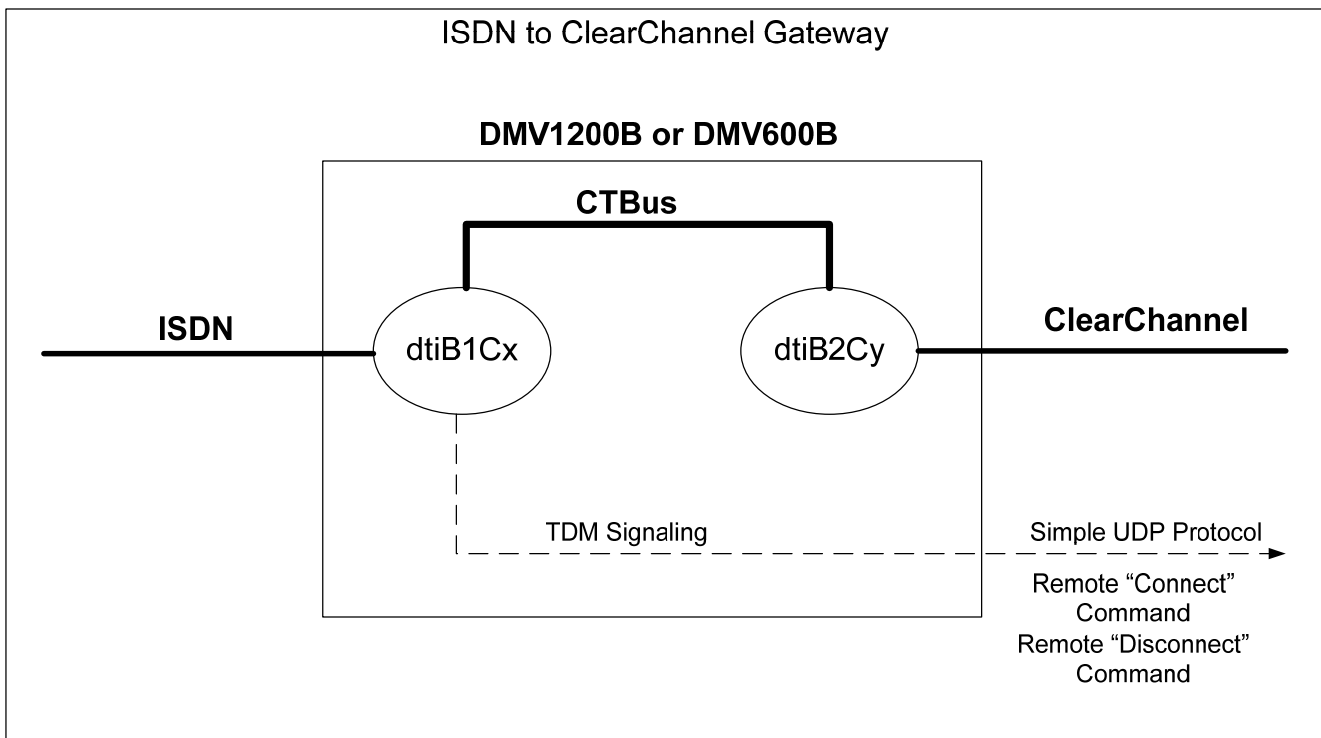

**Figure 2: ISDN to ClearChannel Gateway Configuration**

An ISDN to ClearChannel gateway handles ISDN protocol on one trunk and makes a ‘media only’ connection to ClearChannel on a second trunk. The ISDN to ClearChannel Gateway configuration is described in [“Figure2: ISDN to ClearChannel Gateway Configuration”](#)

An ISDN to ClearChannel Gateway can be configured by setting up a Dialogic DMV600B or Dialogic DMV1200B board with E1 ISDN signaling on trunk 1, E1ClearChannel on trunk 2, and the CTBus configured as ALaw. Alternatively, the board can be set up in a T1 environment with T1 ISDN signaling on trunk 1, T1ClearChannel on trunk 2, and the CTBus configured as MuLaw. Using the Dialogic Global Call API for PSTN network interface connection, an incoming call on the ISDN trunk 1(dtIB1Cx) is routed through the CTBus to the ClearChannel port on trunk 2 (dtIB2Cy) with the appropriate ‘listen’ commands. For call indication purposes, the Simple UDP Socket protocol ([“Appendix I: Simple UDP Socket Protocol”](#)) can be used to send remote “Connect” and “Disconnect” command messages to the m3g-sip\_gateway application. For example code to demonstrate the GlobalCall model, please see the gc\_basic\_call\_model demo code provided with the Dialogic System Release.